

## Polypeptides. Part XXIV.<sup>1</sup> Synthesis of Isariic Acid

By Paul M. Hardy, R. Aubrey Prout, and H. N. Rydon,\* Department of Chemistry, The University, Exeter EX4 4QD

L- and D-3-Hydroxydodecanoylglycyl-L-valyl-D-leucyl-L-alanyl-D-valine (IV) and their methyl esters have been synthesised. The compounds derived from the D-hydroxy-acid were indistinguishable from isariic acid and methyl isariate; this confirmed the amino-acid sequence of isariin, a metabolite of *Isaria cretacea* which liberates isariic acid on alkaline hydrolysis. Predictably, attempts to cyclise the hexapeptide (IV) were unsuccessful: this can be attributed to the presence of the C-terminal valine residue.

THE synthesis of cyclodepsipeptides containing relatively short branched-chain 2-hydroxyalkanoic acids as part of the ring system has been studied extensively (*e.g.* valinomycin,<sup>2</sup> the enniatins,<sup>3</sup> the sporidesmolides,<sup>4</sup> and some analogues of the latter two groups<sup>3,5</sup>), but naturally occurring cyclic compounds containing longer straight-chain 3-hydroxy-acids have received scant synthetic attention. This has not been occasioned by the lack of such compounds in nature, for by 1970 the structures of serratamolide,<sup>6</sup> esperin,<sup>7</sup> isariin,<sup>8,9</sup> the isarolides,<sup>10</sup> and the peptidolipins<sup>11</sup> had been established. These compounds contain hydroxy-acids ranging from 3-hydroxydecanoic to 3-hydroxyeicosanoic acid, but by 1970 only serratamolide had been synthesised. This synthesis, however, is not of general applicability as it involves ring expansion by the hydroxyacyl insertion reaction, and can only be applied to certain cyclodepsipeptides in which a sequence is repeated.<sup>12</sup>

In 1970, therefore, we initiated studies on the synthesis of compounds of this type with the aim of exploring synthetic routes of more general utility. We chose isariin as an appropriate objective; the lack of side-chain functional groups simplifies the synthesis of the linear peptides and peptolides required for cyclisation studies. In isariin the linkage of 3-hydroxydecanoic acid to valine through its hydroxy-group and to glycine

through its carboxy-group was established by chemical methods.<sup>8</sup> The remaining tripeptide sequence (Val-Leu-Ala) was assigned on mass spectral evidence.<sup>9</sup> However, an alternative sequence (Ala-Val-Leu) was proposed after an independent mass spectrometric study.<sup>13</sup>

The conclusions of Wolstenholme and Vining<sup>9</sup> are based on accurate mass measurements of ions derived from both isariin and methyl isariate, and are independent of any chemical evidence. The sequence assignment of the Russian group,<sup>13</sup> however, assumes at one stage in the fragmentation that leucine and not alanine is eliminated. This assumption is based on the fact that carboxypeptidase releases valine, but no other amino-acid, from isariic acid.<sup>8</sup> Vining and Taber<sup>8</sup> suggested this to mean that the D-leucine was in the penultimate position once the valine had been lost. However, Kiryushkin *et al.*<sup>13</sup> interpret the action of the enzyme to mean that D-leucine is exposed as the new C-terminal amino-acid. The lack of a peak with *m/e* 381 then led them to conclude that the alanine residue cannot be attached to leucine.

Although we find the proposals of Wolstenholme and Vining<sup>9</sup> more convincing, the alternative sequence cannot be ruled out conclusively.† Accordingly, our

<sup>7</sup> D. W. Thomas and T. Ito, *Tetrahedron*, 1969, **25**, 1985.

<sup>8</sup> L. C. Vining and W. A. Taber, *Canad. J. Chem.*, 1962, **40**, 1579.

<sup>9</sup> W. A. Wolstenholme and L. C. Vining, *Tetrahedron Letters*, 1966, 2785.

<sup>10</sup> L. H. Briggs, B. J. Fergus, and J. S. Shannon, *Tetrahedron*, 1966, Suppl. 8, p. 269.

<sup>11</sup> M. Barber, W. A. Wolstenholme, M. Guinand, G. Michel, B. C. Das, and E. Lederer, *Tetrahedron Letters*, 1965, 1331; M. Guinand, M. J. Vacheron, G. Michel, B. C. Das, and E. Lederer, *Tetrahedron*, 1966, Suppl. 7, p. 271.

<sup>12</sup> M. M. Shemyakin, Yu. A. Ovchinnikov, V. K. Antonov, A. A. Kiryushkin, V. T. Ivanov, V. I. Shchekolev, and A. M. Schkrob, *Tetrahedron Letters*, 1964, 47.

<sup>13</sup> A. A. Kiryushkin, Yu. A. Ovchinnikov, V. B. Rosinov, and N. S. Wulfson, *Khim. prirod. Soedinenii*, 1966, **2**, 203.

<sup>14</sup> K. Okada, Y. Kurosawa, and M. Hiramoto, *Tetrahedron Letters*, 1972, **26**, 2693.

<sup>15</sup> P. M. Hardy, R. A. Prout, and H. N. Rydon, following paper.

† Since our work began, a preliminary communication<sup>14</sup> outlining a synthesis of isariin has appeared; this is discussed in the following paper.<sup>15</sup>

<sup>1</sup> Part XXIII, H. L. Maia, B. Ridge, and H. N. Rydon, *J.C.S. Perkin I*, 1973, 1972.

<sup>2</sup> M. M. Shemyakin, N. A. Aldanova, E. I. Vinogradova, and M. Yu. Feigina, *Tetrahedron Letters*, 1963, **28**, 1921; B. F. Gisin, R. B. Merrifield, and D. C. Tosteson, *J. Amer. Chem. Soc.*, 1969, **91**, 2691.

<sup>3</sup> M. M. Shemyakin, Yu. A. Ovchinnikov, and V. T. Ivanov, *Angew. Chem. Internat. Edn.*, 1969, **8**, 492.

<sup>4</sup> M. M. Shemyakin, Yu. A. Ovchinnikov, V. T. Ivanov, and A. A. Kiryushkin, *Tetrahedron*, 1963, **19**, 995.

<sup>5</sup> M. M. Shemyakin, Yu. A. Ovchinnikov, V. T. Ivanov, and A. A. Kiryushkin, *Tetrahedron Letters*, 1963, 1927.

<sup>6</sup> H. H. Wasserman, J. J. Keggi, and J. E. McKean, *J. Amer. Chem. Soc.*, 1962, **84**, 2978.

initial synthetic goal was isariic acid, a linear degradation product of isariin obtained by treatment with alkali.<sup>8</sup>

This paper records the synthesis of L- and D-3-hydroxydodecanoylglycyl-L-valyl-D-leucyl-L-alanyl-L-valine (IV) and presents evidence that the latter is identical with isariic acid. Some unsuccessful attempts

ester (II) by using dicyclohexylcarbodi-imide.<sup>18</sup> Despite the unprotected hydroxy-group, a yield of 70% of the desired peptolide was obtained. Shemyakin *et al.*<sup>19</sup> first showed the applicability of this convenient method in the preparation of depsipeptides related to esperinic acid, and a preliminary experiment with glycine ethyl

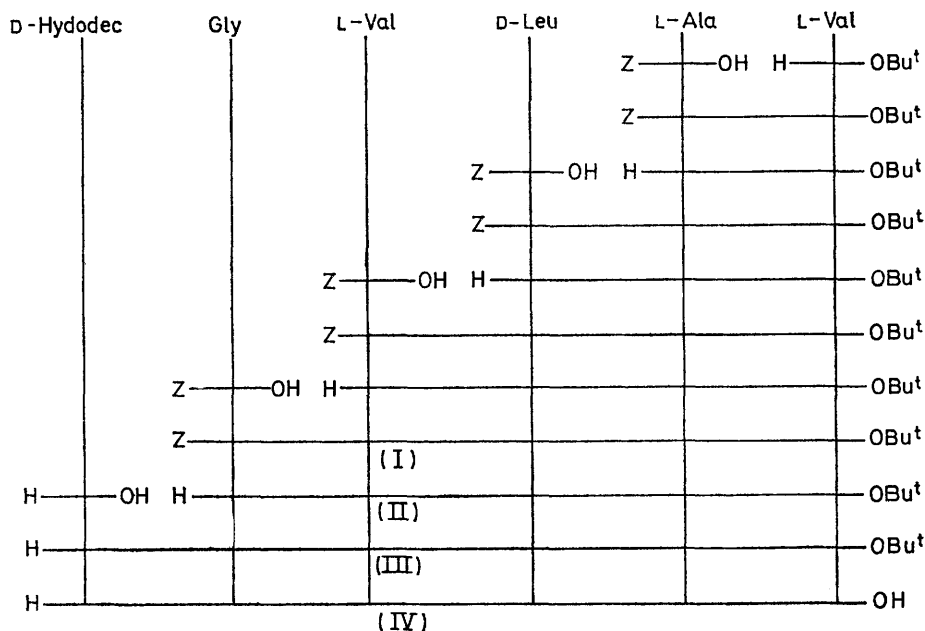

SCHEME Here and elsewhere abbreviations for amino-acid residues, *etc.*, are those recommended by I.U.P.A.C.-I.U.B. (*Biochem. J.*, 1972, **126**, 773).

at cyclisation are described; a successful synthesis of isariin is detailed in the following paper.<sup>15</sup>

The synthetic strategy adopted (Scheme) involved incorporation of the hydroxy-acid at the last stage. The pentapeptide derivative glycyl-L-valyl-D-leucyl-L-alanyl-L-valine t-butyl ester (II) was built up from L-valine t-butyl ester in an overall yield of 48.5% by alternate coupling with *N*-benzyloxycarbonylamino-acids and catalytic hydrogenolysis. Peptide bonds were formed by the mixed anhydride method;<sup>16</sup> this gave clean products in yields decreasing from 95 to 79% as the chain length increased. The ease of hydrogenolysis fell as the synthesis proceeded, and more severe conditions were required with the higher members. Most of the peptides below the tetrapeptide level could not be crystallised, but their free amino-esters were characterised as either crystalline hydrochlorides or oxalates. All tetra- and penta-peptide derivatives obtained were crystalline.

DL-3-Hydroxydodecanoic acid was synthesised in one step from decanal and t-butyl 2-bromoacetate by a modified Reformatskii procedure.<sup>17</sup> Resolution was effected with D-amphetamine.<sup>8</sup> D-3-Hydroxydodecanoic acid was coupled to the pentapeptide t-butyl

ester confirmed its utility for our purpose. Removal of the t-butyl ester group from the peptolide (III) with hydrogen chloride in dioxan gave D-3-hydroxydodecanoylglycyl-L-valyl-D-leucyl-L-alanyl-L-valine (III) in high yield.

This material was compared with isariic acid prepared from a sample of isariin generously provided by Professor L. C. Vining. The compounds had similar m.p.s, although these are not very sharp, and identical i.r. spectra. The optical rotations of solutions in two solvents (ethanol and pyridine) are in agreement. To facilitate mass spectral and chromatographic comparisons, specimens of the methyl esters of both isariic acid and our synthetic material (IV) were prepared by treatment with diazomethane. These esters had i.r. spectra, optical rotations, and mass spectra which corresponded very closely. Furthermore, they were not separable by reverse-phase high pressure liquid chromatography (h.p.l.c.), even on prolonged recycling. The number of theoretical plates of this type of system is such that it can be made a very sensitive test for chemical identity. However, appropriate safeguards must be taken to ensure that apparent homogeneity on co-chromatographing the samples is in fact due to

<sup>16</sup> J. R. Vaughan and R. L. Osato, *J. Amer. Chem. Soc.*, 1951, **73**, 5553.

<sup>17</sup> D. A. Cornforth, A. E. Opara, and G. Read, *J. Chem. Soc. (C)*, 1969, 2799.

<sup>18</sup> J. C. Sheehan and G. P. Hess, *J. Amer. Chem. Soc.*, 1955, **77**, 1067.

<sup>19</sup> Yu. A. Ovchinnikov, V. T. Ivanov, P. V. Kostetsky, and M. M. Shemyakin, *Tetrahedron Letters*, 1966, 5285.

chemical identity and not simply to selection of a system of inadequate resolving power.

Accordingly, L-3-hydroxydodecanoylglycyl-L-valyl-D-leucyl-L-alanyl-L-valine methyl ester was also prepared. This stereoisomer could not be adequately differentiated from its epimer on the basis of its i.r. or mass spectra, although its optical rotation was about half that of methyl isariate. Its general similarity to methyl isariate made it a suitable compound for testing the resolving power of our chromatographic system. In the event it was clearly distinguishable from methyl isariate by h.p.l.c. on an eight foot column of Bondapak-C<sub>18</sub> on Porasil B [acetonitrile-water (3:1 v/v) as eluant]. Ten recycles were required for a complete separation, although some resolution was apparent after the first recycle. Under the same conditions an equimolar mixture of methyl isariate and our synthetic peptolide (IV) ran as a single symmetrical peak.

We feel that this evidence satisfactorily establishes the chemical identity of the natural and synthetic materials, and confirms the amino-acid sequence proposed by Wolstenholme and Vining.<sup>9</sup>

Although several cyclic peptides and peptolides containing valine have been synthesised, none of the linear precursors contained valine at the C-terminus. Acceptable yields are obtained on cyclisation when this amino-acid is at the N-terminus,<sup>20</sup> but when it is C-terminal peptide bond formation and other reactions are subject to steric hindrance.<sup>21</sup> Synthetic strategies which avoid this unfavourable situation are therefore normally adopted. Having prepared synthetic isariic acid we were in a position to attempt to cyclise it to isariin, but because of this steric hindrance and the probability of extensive racemisation during coupling this route held out little prospect of success. However, we had enough material to be able to try several different methods of cyclisation in an attempt to prepare at least a small quantity of isariin by this route. Chromatography of the products obtained by the acid chloride method,<sup>22</sup> the Brockmann method (acetyl chloride and imidazole),<sup>23</sup> carbonyldi-imidazole,<sup>24</sup> and dicyclohexylcarbodi-imide in pyridine<sup>25</sup> showed no material corresponding to isariin. Likewise, attempts to induce lactonisation by using 2,4,6-tri-isopropylbenzenesulphonyl chloride,<sup>26</sup> *NN*-dimethylformamide dineopentyl acetal,<sup>27</sup> and a polyphosphate ester<sup>28</sup> also failed. It therefore became necessary to synthesise an alternative linear sequence: the preparation of this and its successful cyclisation to isariin are described in the succeeding paper.

#### EXPERIMENTAL

The purity of all compounds was confirmed by t.l.c. on Kieselgel GF 254, usually by examination in each of three

<sup>20</sup> See, for example, R. Schwyzer and P. Sieber, *Helv. Chim. Acta*, 1957, **40**, 624; 1958, **41**, 286.

<sup>21</sup> E. Schröder, and K. Lübke, 'The Peptides,' Academic Press, New York, 1965, vol. I, p. 138.

<sup>22</sup> M. M. Shemyakin, Yu. A. Ovchinnikov, A. A. Kiryushkin, and V. T. Ivanov, *Tetrahedron*, 1963, **19**, 581.

<sup>23</sup> H. Brockmann and H. Lackner, *Chem. Ber.*, 1968, **101**, 1312.

solvent systems. Compounds with free amino-groups were located by spraying with 0.3% ninhydrin in *n*-butanol and heating at 100° for 10 min, and *N*-acyl compounds by the chlorine-starch-iodide method.<sup>29</sup> Organic solutions were dried over magnesium sulphate and evaporated or concentrated at 10–20 mmHg on a rotary evaporator.

Optical rotations were measured with a Bendix-NPL 143 polarimeter, i.r. spectra were recorded on a Hilger-Watts Infracan H 900 spectrometer, and mass spectra were determined on a Hitachi-Perkin-Elmer RMU-6 spectrometer and also by the Physico-Chemical Measurements Unit at Harwell. N.m.r. spectra were recorded at 33.5° on either a Perkin-Elmer R10 60 MHz spectrometer or a JEOL JMH-100 100 MHz instrument, and amino-acid analyses were run on a JEOL JLC-5AH amino-acid analyser.

*Synthesis of D- and L-3-Hydroxydodecanoic Acids.*—DL-3-Hydroxydodecanoic acid. The one-step 3-hydroxyalkanoic acid synthesis developed by Read and his colleagues<sup>17</sup> was applied to decanal. To a stirred suspension of granulated zinc (41 g, 0.6 mol) in dry tetrahydrofuran (500 ml) containing a few crystals of iodine was added a portion of a solution of *t*-butyl bromoacetate (67 g, 0.34 mol) and freshly distilled decanal (31.26 g, 0.2 mol) in dry tetrahydrofuran (500 ml). The mixture was heated to 75°, and once the reaction had started (as evidenced by a cloudiness in the solution and loss of the iodine colour), the remainder of the solution was added dropwise to the refluxing mixture during 1 h. The mixture was stirred for a further 1 h under reflux, then the tetrahydrofuran was distilled off. The last traces of solvent were removed in a 120° oil-bath and the residual Reformatskii adduct was heated under reflux with benzene (1 l) for 2 h. The cooled solution was concentrated, 2*M*-hydrochloric acid (1 l) was added, and the mixture was extracted with ethyl acetate (3 × 300 ml). The combined organic extracts were washed with *m*-sodium hydrogen carbonate (4 × 100 ml); the combined extracts were acidified to pH 2 with concentrated hydrochloric acid and then re-extracted with ethyl acetate (3 × 200 ml). The ethyl acetate solution was dried and evaporated *in vacuo*, and the crude crystalline residue recrystallised from light petroleum (b.p. 60–80°) to give the pure hydroxy-acid (30 g, 69%), m.p. 67–68° (lit.,<sup>8</sup> 68.3–69.2°);  $\tau$  (60 MHz; CDCl<sub>3</sub>) 2.75br (2H, s, partially D<sub>2</sub>O-exchangeable, OH and CO<sub>2</sub>H), 6.0 (1H, complex,  $\beta$ -CH<sub>2</sub>), 7.53 (2H, d,  $\alpha$ -CH<sub>2</sub>), 8.75br (16H, s, side-chain CH<sub>2</sub>s), and 9.15 (3H, d, Me);  $\nu_{\max}$ . (KBr) 3550, 2970, 2930, 2860, and 1685 cm<sup>-1</sup> (Found: C, 66.5; H, 11.55. Calc. for C<sub>12</sub>H<sub>24</sub>O<sub>3</sub>; C, 66.6; H, 11.2%).

*Resolution of DL-3-hydroxydodecanoic acid.*<sup>8</sup> A solution of *D*-amphetamine (33.0 g, 0.232 mol) in ether (50 ml) was added to a stirred solution of the racemic hydroxy-acid (50.1 g, 0.232 mol) in ether (1200 ml). The precipitate which formed was redissolved by adding just sufficient ethanol to the suspension under reflux, and the solution was left to cool to 20°. Filtration afforded a solid which was recrystallised from ethereal ethanol to give the pure *DD*-

<sup>24</sup> H. A. Staab, *Chem. Ber.*, 1956, **89**, 1927.

<sup>25</sup> S. Kuyama and S. Tamura, *Agric. Biol. Chem.*, 1965, **29**, 168.

<sup>26</sup> R. Lohrmann, D. Söll, H. Hayatsu, E. Ohtsuka, and H. G. Khorana, *J. Amer. Chem. Soc.*, 1966, **88**, 819.

<sup>27</sup> H. Büchi, K. Steen, and A. Eschenmoser, *Angew. Chem. Internat. Edn.*, 1964, **3**, 62.

<sup>28</sup> G. Schramm, H. Graetsch, and W. Pollman, *Angew. Chem. Internat. Edn.*, 1962, **1**, 1.

<sup>29</sup> H. N. Rydon and P. W. G. Smith, *Nature*, 1952, **169**, 922.

amphetamine salt (34.35 g), m.p. 119—121° (lit.,<sup>8</sup> 119—121°),  $[\alpha]_D^{20}$  -14.0° (*c* 2.0 in  $\text{CHCl}_3$ ). This material was partitioned between 2*M*-hydrochloric acid and ether; the ethereal layer was dried and evaporated, and the residue crystallised from light petroleum (b.p. 60—80°) to give *D*-3-hydroxydodecanoic acid (21.8 g), m.p. 59.5—60.5° (lit.,<sup>8</sup> 62.5—63.5°; lit.,<sup>30</sup> 60—60.5°; lit.,<sup>31</sup> 62.5—63°),  $[\alpha]_D^{20}$  -15.8° (*c* 1.6 in  $\text{CHCl}_3$ ) {lit.,<sup>8</sup>  $[\alpha]_D^{25}$  -15.2° (*c* 1.6 in  $\text{CHCl}_3$ ); lit.,<sup>30</sup>  $[\alpha]_D^{17}$  -16.1° (*c* 5.0 in  $\text{CHCl}_3$ ); lit.,<sup>31</sup>  $[\alpha]_D^{19}$  -15.9° (*c* 1.5 in  $\text{CHCl}_3$ )}. The mother liquor left after removal of the *DD*-amphetamine salt was cooled to -40°. The feathery needles formed were filtered off; recrystallisation from ethereal ethanol gave the *LD*-amphetamine salt (40.2 g), m.p. 78—79° (lit.,<sup>8</sup> 78—79°),  $[\alpha]_D^{20}$  +16.9° (*c* 2.5 in  $\text{CHCl}_3$ ). The free acid was regenerated by the procedure described for the *D*-isomer; recrystallisation from light petroleum (b.p. 60—80°) gave *L*-3-hydroxydodecanoic acid (22.3 g), m.p. 60—62.5° (lit.,<sup>8</sup> 62—63.2°; lit.,<sup>31</sup> 62.5—63.5°),  $[\alpha]_D^{20}$  +15.2° (*c* 2.8 in  $\text{CHCl}_3$ ) {lit.,<sup>8</sup>  $[\alpha]_D^{25}$  +15.6° (*c* 2.1 in  $\text{CHCl}_3$ ); lit.,<sup>31</sup>  $[\alpha]_D^{19}$  +15.1° (*c* 1.6 in  $\text{CHCl}_3$ )}. (Found: C, 66.1; H, 11.4. Calc. for  $\text{C}_{12}\text{H}_{24}\text{O}_3$ : C, 66.6; H, 11.2%).

**L-Valine *t*-Butyl Ester.**—A solution of *N*-benzyloxycarbonyl-*L*-valine (47.0 g, 0.187 mol) in dichloromethane (220 ml) containing concentrated sulphuric acid (2 ml) was chilled in a pressure bottle and liquid isobutene (350 ml) was added. The bottle was stoppered and left at 20° for 3 days. After recooling to 0° the bottle was opened, the excess of isobutene was allowed to evaporate, and the residual mixture was washed with *m*-sodium hydrogen carbonate (4 × 60 ml) and water (4 × 80 ml). The organic solution was dried and the solvent evaporated off to leave oily *N*-benzyloxycarbonyl-*L*-valine *t*-butyl ester (47.8 g, 83%),  $[\alpha]_D^{20}$  -19.7° (*c* 1.8 in MeOH),  $n_D^{25}$  1.4875 (lit.,<sup>32</sup>  $n_D^{20}$  1.4887);  $\tau$  (60 MHz;  $\text{CDCl}_3$ ) 2.70 (5H, s, Ph), 4.60 (1H,  $\text{D}_2\text{O}$ -exchangeable, NH), 4.90 (2H, s, benzyl  $\text{CH}_2$ ), 5.80 (1H, q,  $\alpha$ -CH), 7.88 (1H, complex, side-chain CH), 8.35 (9H, s,  $\text{Bu}^t$ ), 9.05 (3H, d, Me of  $\text{Pr}^t$ ), and 9.15 (3H, d, Me of  $\text{Pr}^t$ ). Part of this ester (30.5 g, 0.098 mol) was dissolved in methanol (150 ml) and hydrogenated (22°; 760 mmHg) over palladised charcoal (5%; 3.5 g) for 4 h. Filtration and evaporation left oily *L*-valine *t*-butyl ester (16.6 g, 97.5%),  $[\alpha]_D^{25}$  -50.95° (*c* 1.1 in MeOH),  $n_D^{23}$  1.4250 (lit.,<sup>32</sup>  $n_D^{20}$  1.4265). A sample of this product was converted into its hydrochloride by adding a slight excess of ethereal 5*M*-hydrogen chloride to a solution in ether (3  $\text{cm}^3$   $\text{g}^{-1}$ ). The crystalline precipitate was filtered off, washed with ether, and dried *in vacuo* to give the pure hydrochloride (98.3%), m.p. 142—144° (lit.,<sup>33</sup> 147—149°; lit.,<sup>34</sup> 140—144°),  $[\alpha]_D^{27}$  +20.25° (*c* 1.6 in EtOH) {lit.,<sup>33</sup>  $[\alpha]_D^{25}$  +20.5° (*c* 2.0 in EtOH)}.

**Oligopeptide Derivatives.**—Mixed anhydride couplings<sup>16</sup> were carried out by the following general procedure. A solution of the *N*-benzyloxycarbonylamino-acid (0.04—0.10 mol) in dry tetrahydrofuran (150—500 ml) containing triethylamine (1 equiv.) was cooled to -10° before the addition of isobutyl chloroformate (1 equiv.). The mixture was stirred at -10° for 10 min and a solution of amino-acid or peptide *t*-butyl ester (1 equiv.) in dry tetrahydrofuran (50—250 ml) was added dropwise over 30 min at -10°. The mixture was stirred overnight at 20°, then filtered, and the solvent was evaporated off. The residue was dissolved

in ethyl acetate and washed in succession with 2*M*-hydrochloric acid, water, *m*-sodium hydrogen carbonate, water, and brine. The organic solution was dried and evaporated to give the protected peptide.

*N*-Benzyloxycarbonyl-peptide *t*-butyl esters were hydrogenolysed according to the following general procedure. The protected peptide (0.05—0.10 mol) in aqueous *t*-butyl alcohol (95% v/v; 100—200 ml) was hydrogenated over palladised charcoal (3—5 g; 5%). Filtration, evaporation, dissolution of the residue in *n*-hexane, and evaporation of the solution *in vacuo* yielded the peptide ester.

Condensation of *N*-benzyloxycarbonyl-*L*-alanine (14.18 g, 0.064 mol) with *L*-valine *t*-butyl ester by the mixed anhydride method gave oily *N*-benzyloxycarbonyl-*L*-alanyl-*L*-valine *t*-butyl ester (23.0 g, 95.5%),  $[\alpha]_D^{20}$  -36.4° (*c* 2.0 in MeOH),  $n_D^{25}$  1.4906;  $\tau$  (60 MHz;  $\text{CDCl}_3$ ) 2.7 (5H, s, Ph), 3.17 [1H, d, *J* 8.4 Hz,  $\text{D}_2\text{O}$ -exchangeable,  $\text{NH}_{(1)}$ ], 4.16 [1H, d, *J* 7.5 Hz,  $\text{D}_2\text{O}$ -exchangeable,  $\text{NH}_{(2)}$ ], 4.9 (2H, s, benzyl  $\text{CH}_2$ ), 5.6 (2H, complex,  $\alpha_{1,2}$ -CH), 8.0 (1H, complex, CH of  $\text{Pr}^t$ ), 8.52 (9H, s,  $\text{Bu}^t$ ), 8.6 (3H, d, Ala-Me), and 9.1 (6H, d, side-chain  $\text{Me}_2$  of  $\text{Pr}^t$ ) (amino-acid ratio Ala 1.08; Val 1.00). Catalytic hydrogenolysis of this ester (20 g, 0.053 mol) for 3 h at 20° and 760 mmHg gave *L*-alanyl-*L*-valine *t*-butyl ester (12.9 g, 99%), as a non-crystallisable oil. This was dissolved in diethyl ether (20 ml) and added to a solution of anhydrous oxalic acid (4.3 g, 0.053 mol) in diethyl ether (20 ml). The precipitate was recrystallised from ethereal ethanol to give the pure *hydrogen oxalate* of *L*-alanyl-*L*-valine *t*-butyl ester (11.0 g, 62.4%), m.p. 142—144°,  $[\alpha]_D^{27}$  -19.6° (*c* 1.2 in MeOH) (Found: C, 48.9; H, 8.3; N, 8.2.  $\text{C}_{14}\text{H}_{26}\text{N}_2\text{O}_7$ , 0.5 $\text{H}_2\text{O}$  requires C, 49.0; H, 7.9; N, 8.2%).

Mixed anhydride coupling of *N*-benzyloxycarbonyl-*D*-leucine (19.41 g, 0.073 mol) with *L*-alanyl-*L*-valine *t*-butyl ester (17.80 g, 0.073 mol; obtained from the hydrogen oxalate by washing an ethereal suspension with *m*-sodium hydrogen carbonate and water, and evaporating) gave, after one recrystallisation from ethyl acetate-light petroleum (b.p. 40—60°), *N*-benzyloxycarbonyl-*D*-leucyl-*L*-alanyl-*L*-valine *t*-butyl ester (33.72 g, 94.2%), m.p. 97—98°,  $[\alpha]_D^{23}$  -22.8° (*c* 0.4 in MeOH) (Found: C, 63.8; H, 8.5; N, 8.9.  $\text{C}_{26}\text{H}_{41}\text{N}_3\text{O}_6$  requires C, 63.5; H, 8.4; N, 8.55%) (amino-acid ratio Leu, 1.00; Ala, 0.91; Val, 1.03). Catalytic hydrogenolysis of part of this material (21.38 g, 0.044 mol) for 6 h at 20° and 4 atm gave *D*-leucyl-*L*-alanyl-*L*-valine *t*-butyl ester (13.22 g, 85.5%) as a foam. The bulk of this material (10.0 g, 0.028 mol) was dissolved in ether (50 ml) and added to a solution of anhydrous oxalic acid (2.52 g, 0.028 mol) in ether (50 ml). Recrystallisation of the precipitate from ethanol-ether afforded the pure *hydrogen oxalate* of *D*-leucyl-*L*-alanyl-*L*-valine *t*-butyl ester (9.71 g, 77.6%), m.p. 90—94°,  $[\alpha]_D^{23}$  -56.7° (*c* 1.9 in EtOH) (Found: C, 53.9; H, 8.45; N, 9.8.  $\text{C}_{20}\text{H}_{37}\text{N}_3\text{O}_8$  requires C, 53.7; H, 8.3; N, 9.4%).

Coupling *N*-benzyloxycarbonyl-*L*-valine (7.39 g, 0.037 mol) with *D*-leucyl-*L*-alanyl-*L*-valine *t*-butyl ester (13.22 g, 0.037 mol; liberated from the hydrogen oxalate as in the case of the dipeptide) gave, after one recrystallisation from aqueous methanol, the protected tetrapeptide *N*-benzyloxycarbonyl-*L*-valyl-*D*-leucyl-*L*-alanyl-*L*-valine *t*-butyl ester (18.24 g, 83.6%), m.p. 183—186°,  $[\alpha]_D^{20}$  -16.3° (*c* 1.0 in MeOH) (Found: C, 63.2; H, 8.9; N, 9.8.  $\text{C}_{31}\text{H}_{50}\text{N}_4\text{O}_7$  requires C,

<sup>32</sup> G. W. Anderson and F. M. Callahan, *J. Amer. Chem. Soc.*, 1960, **82**, 3359.

<sup>33</sup> R. Roeske, *J. Org. Chem.*, 1963, **281**, 1251.

<sup>34</sup> E. Schröder and K. Lübke, *Annalen*, 1962, **655**, 211.

<sup>30</sup> C. D. Baker and F. D. Gunstone, *J. Chem. Soc.*, 1963, 759.

<sup>31</sup> M. Hiramoto, K. Okada, S. Nagai, and H. Kawamoto, *Chem. and Pharm. Bull. (Japan)*, 1971, **19**, 1308.

63.0; H, 8.5; N, 9.5%) (amino-acid ratio Leu, 1.00; Ala, 0.90; Val, 2.08). This product (18.04 g, 0.030 mol) was hydrogenated in the usual way at 40° for 6 h at 4 atm. Recrystallisation of the crude residue from methanol-diisopropyl ether gave pure *L-valyl-D-leucyl-L-alanyl-L-valine t-butyl ester* (13.9 g, 98.6%), m.p. 185–187°,  $[\alpha]_D^{25} - 2.5^\circ$  (*c* 0.9 in MeOH) (Found: C, 56.1; H, 9.45; N, 11.4.  $C_{28}H_{44}N_4O_6 \cdot 2H_2O$  requires C, 56.1; H, 9.8; N, 11.4%).

Finally, mixed anhydride coupling of *N*-benzyloxycarbonylglycine (19.56 g, 0.094 mol) with *L-valyl-D-leucyl-L-alanyl-L-valine t-butyl ester* (42.7 g, 0.094 mol) gave, after recrystallisation from aqueous methanol, *N-benzyloxycarbonylglycyl-L-valyl-D-leucyl-L-alanyl-L-valine t-butyl ester* (I) (47.84 g, 79%), m.p. 195–197°,  $[\alpha]_D^{25} - 12.3^\circ$  (*c* 1.6 in MeOH) (Found: C, 61.2; H, 8.5; N, 11.0.  $C_{33}H_{53}N_5O_8$  requires C, 61.2; H, 8.25; N, 10.8%) (amino-acid ratio Gly, 0.97; Ala, 1.09; Val, 2.14; Leu, 0.95). Hydrogenation of part of this material (9.0 g, 0.139 mol) at 50° and 10 atm for 8 h gave, after one recrystallisation from methanol-light petroleum (b.p. 60–80°), *glycyl-L-valyl-D-leucyl-L-alanyl-L-valine t-butyl ester* (II) (6.75 g, 98%), m.p. 194–196°,  $[\alpha]_D^{24} - 16.8^\circ$  (*c* 1.4 in MeOH) (Found: C, 58.2; H, 9.6; N, 12.9.  $C_{25}H_{47}N_5O_8$  requires C, 58.45; H, 9.2; N, 13.6%) (amino-acid ratio Gly, 1.00; Ala, 0.99; Val, 2.11; Leu, 1.04).

**Peptolide Derivatives.**—*Ethyl L-2-hydroxydodecanoyl glycinate*. A solution of *L-3-hydroxydodecanoic acid* (0.25 g, 1.17 mmol) and glycine ethyl ester (0.12 g, 1.17 mmol) in dichloromethane (20 ml) was cooled to –10° and dicyclohexylcarbodi-imide (0.27 g, 1.29 mmol) was added. The mixture was stirred overnight at 20°, a drop of acetic acid was added, and the suspension was stirred for a further 10 min, then filtered. The filtrate was washed with 2*M*-hydrochloric acid, water, *m*-sodium hydrogen carbonate, water, and brine, and then evaporated. The residue was taken up in the minimum amount of acetone and the solution kept at –10° for 12 h. A small amount of dicyclohexylurea was filtered off, and the solvent was removed. The residue was chromatographed on a column of silica gel (30 × 2 cm; 10 g; Merck Kieselgel G) and eluted with chloroform-methanol (4:1 v/v). The major fraction gave, after one recrystallisation from ethyl acetate-light petroleum (b.p. 60–80°), pure *L-3-hydroxydodecanoyl-glycine ethyl ester* (0.20 g, 58.2%), m.p. 78.5–80°,  $[\alpha]_D^{23} + 4.4^\circ$  (*c* 0.45 in EtOH);  $\tau$  (60 MHz;  $CDCl_3$ ) 3.20 (1H, complex,  $D_2O$ -exchangeable, NH), 5.60–6.10 (5H, complex, Gly- $CH_2$ , ester  $CH_2$ ,  $\beta$ -CH of hydroxy-acid), 6.45br (1H, s,  $D_2O$ -exchangeable, OH), 7.65 (2H, d,  $\alpha$ - $CH_2$  of hydroxy acid), 8.70br (19H, s, ester Me, aliphatic  $CH_2$ ), and 9.15br (3H, s, Me of hydroxy-acid);  $\nu_{max}$  (KBr) 3400, 1730, 1650, and 1550  $cm^{-1}$  (Found: C, 63.8; H, 10.2; N, 5.1%; *m/e*, 301.  $C_{16}H_{21}NO_4$  requires C, 63.75; H, 10.4; N, 4.7%; *M*, 301).

*D-3-Hydroxydodecanoylglycyl-L-valyl-D-leucyl-L-alanyl-L-valine t-butyl ester* (III). A solution of *D-3-hydroxydodecanoic acid* (2.40 g, 0.011 mol) and *glycyl-L-valyl-D-leucyl-L-alanyl-L-valine t-butyl ester* (5.71 g, 0.011 mol) in dichloromethane (150 ml) was cooled to –10° and dicyclohexylcarbodi-imide (2.52 g, 0.0122 mol) was added. The mixture was stirred overnight at 20° and worked up in the same way as in the ethyl *L-3-hydroxydodecanoylglycinate* preparation. The crude product was chromatographed on a column of silica gel (200 g; 200 × 5 cm, Merck Kieselgel G) and eluted with chloroform-ethanol (98:2 v/v). The major fraction crystallised from aqueous ethanol to give the

pure *peptolide* (III) (5.6 g, 70%), m.p. 184–186°,  $[\alpha]_D^{25} - 6.3^\circ$  (*c* 1.1 in EtOH) (Found: C, 62.7; H, 10.1; N, 9.9%; *m/e*, 711.  $C_{27}H_{49}N_5O_8$  requires C, 62.4; H, 9.8; N, 9.8%; *M*, 711). *L-3-Hydroxydodecanoylglycyl-L-valyl-D-leucyl-L-alanyl-L-valine t-butyl ester* was prepared from *L-3-hydroxydodecanoic acid* (1.10 g, 5.1 mmol) in a similar way. Again crystallisation from aqueous ethanol gave the pure protected *peptolide* (2.58 g, 71%), m.p. 152–154°,  $[\alpha]_D^{25} - 8.6^\circ$  (*c* 1.3 in EtOH) (Found: C, 62.4; H, 9.8; N, 9.5.  $C_{27}H_{49}N_5O_8$  requires C, 62.4; H, 9.8; N, 9.8%).

*D-3-Hydroxydodecanoylglycyl-L-valyl-D-leucyl-L-alanyl-L-valine* (IV). This free peptolide was prepared by treating the *t*-butyl ester (III) (0.21 g, 0.29 mmol) with a solution of hydrogen chloride in dioxan (3.7*M*; 8 ml, 3.71 mmol). The resulting solution was kept at 20° for 12 h before evaporation. The residue was dissolved in a little water which was then evaporated off. This flushing was repeated before dissolving the product in 2*M*-ammonium hydroxide (20 ml) and extracting three times with chloroform. The combined extracts were washed with 2*M*-ammonium hydroxide and the combined aqueous solutions acidified to pH 2 with concentrated hydrochloric acid. The precipitate was washed with water and dried to yield the *free peptolide* (IV) (0.19 g, 96%), m.p. 194–198°,  $[\alpha]_D^{25} - 5.2^\circ$  (*c* 5.0 in EtOH),  $[\alpha]_D^{25} - 9.6^\circ$  (*c* 5.0 in  $C_6H_5N$ );  $\nu_{max}$  (KBr) 3320, 1735, 1645, and 1545  $cm^{-1}$ ;  $\tau$  (100 MHz;  $[(CD_3)_2SO]$ ) 1.6–2.3 (5H, complex,  $D_2O$ -exchangeable,  $NH_{1-5}$ ), 5.6–6.0 (5H, complex,  $\alpha_{1-4}$ -CH,  $\beta$ -CH of hydroxy-acid), 6.16 (2H, d, Gly- $CH_2$ ), 7.82 (2H, d, *J* 6 Hz, hydroxy-acid  $\alpha$ - $CH_2$ ), 8.10 (3H, complex, side-chain CH), 8.54 (2H, complex, side-chain  $CH_2$ ), 8.76br (19H, s, aliphatic  $CH_2$ s, Ala-Me), and 9.12 (21H, t, side-chain Me) (Found: C, 60.7; H, 9.5; N, 10.4.  $C_{33}H_{61}N_5O_8$  requires C, 60.4; H, 9.4; N, 10.7%) (amino-acid ratio Gly, 0.91; Ala, 1.00; Val, 2.00; Leu, 1.13). A portion of this material (0.10 g, 0.153 mmol) was dissolved in methanol (5 ml), cooled to 4°, and treated with ethereal diazomethane. The excess of diazomethane was destroyed with acetic acid and the solvent was evaporated off. Crystallisation of the residue from aqueous methanol gave *D-3-hydroxydodecanoylglycyl-L-valyl-D-leucyl-L-alanyl-L-valine methyl ester* (62 mg, 61%), m.p. 196–198°,  $[\alpha]_D^{24} - 15.2^\circ$  (*c* 1.0 in MeOH);  $\nu_{max}$  (KBr) 3280, 3080, 2930, 1735, 1630, and 1530  $cm^{-1}$  (Found: C, 59.4; H, 9.4; N, 10.1%; *m/e*, 669.  $C_{34}H_{63}N_5O_8 \cdot H_2O$  requires C, 59.4; H, 9.2; N, 10.2%; *M* –  $H_2O$ , 669).

*L-3-Hydroxydodecanoylglycyl-L-valyl-D-leucyl-L-alanyl-L-valine*.—This compound was prepared from its *t*-butyl ester (0.28 g, 0.39 mmol) as described for the epimer. Material precipitated from ammonium hydroxide solution, on washing with water and drying, gave the pure *free peptolide* (0.19 g, 96%), m.p. 196–202°,  $[\alpha]_D^{25} - 4.5^\circ$  (*c* 4.0 in EtOH),  $[\alpha]_D^{25} - 2.7^\circ$  (*c* 3.0 in  $C_6H_5N$ ) (Found: C, 60.8; H, 9.45; N, 10.1.  $C_{33}H_{61}N_5O_8$  requires C, 60.4; H, 9.4; N, 10.7%) (amino-acid ratio Gly, 1.00; Ala, 0.96; Val, 2.10; Leu, 1.10). A portion of this material (0.10 g, 0.153 mmol) was esterified with diazomethane as described for its diastereoisomer to give *L-3-hydroxydodecanoylglycyl-L-valyl-D-leucyl-L-alanyl-L-valine methyl ester* (63.3 mg, 62.2%), m.p. 204–207°,  $[\alpha]_D^{24} - 8.7^\circ$  (*c* 1.0 in MeOH);  $\nu_{max}$  (KBr) 3280, 3080, 2930, 1735, 1630, and 1530  $cm^{-1}$  (Found: C, 59.3; H, 9.5; N, 10.0%; *m/e*, 669.  $C_{34}H_{63}N_5O_8 \cdot H_2O$  requires C, 59.4; H, 9.2; N, 10.2%; *M* –  $H_2O$ , 669).

*Alkaline Hydrolysis of Natural Isariin*.<sup>8</sup>—Natural isariin (20.0 mg, 0.314 mmol) (purified by h.p.l.c.) was dissolved

in methanol (4 ml) and 0.1M-potassium hydroxide solution was added. After 2 days at 37° the solution was acidified with 0.1M-hydrochloric acid (2 ml) and cooled to 0°. The gelatinous precipitate was separated, washed with water, and dried at 70° to give pure isariic acid (17.9 mg, 87%), m.p. 195–199°,  $[\alpha]_D^{24}$   $-4.9^\circ$  (*c* 0.3 in EtOH),  $[\alpha]_D^{23}$   $-9.3^\circ$  (*c* 0.3 in C<sub>6</sub>H<sub>5</sub>N);  $\nu_{\max}$  (KBr) 3320, 1735, 1645, and 1545 cm<sup>-1</sup> [lit.,<sup>8</sup> m.p. 194–200°;  $\nu_{\max}$  (KBr) 1727, 1635, and 1543 cm<sup>-1</sup>]. A sample of this was converted as described for our synthetic peptolides into *methyl isariate*, m.p. 196–198°,  $[\alpha]_D^{26}$   $-15.8^\circ$  (*c* 0.4 in MeOH);  $\nu_{\max}$  (KBr) 3280, 3080, 2930, 1735, 1630, and 1530 cm<sup>-1</sup> (Found: C, 58.9; H, 9.5; N, 9.7. C<sub>34</sub>H<sub>63</sub>N<sub>5</sub>O<sub>9</sub>·H<sub>2</sub>O requires C, 59.4; H, 9.2; N, 10.2%).

**High Pressure Liquid Chromatography.**—A Waters ALC-100 high-pressure liquid chromatograph with a differential refractometer detector was used. The best resolution for our type of compound was obtained with a reverse phase system: Bondapak-C<sub>18</sub> bonded to Corasil (analytical column) or Porasil B (preparative scale column). The analytical system consisted of two coupled 2 ft × 2.3 mm diam. stainless steel columns and the preparative system of four coupled 2 ft ×  $\frac{3}{8}$  in diam. stainless steel columns, both run at a flow rate of 2 ml min<sup>-1</sup>. A constant and reproducible flow rate was assured by the use of a model 6000 Solvent Delivery System. Elution was carried out with acetonitrile–water (3 : 1 v/v). Samples were injected in methanol (10  $\mu$ l of an 8 mg ml<sup>-1</sup> solution in the analytical experiments and 2 ml containing 20–50 mg of peptolide in the case of the preparative separations). The following elution volumes (in ml) were observed on analytical h.p.l.c. evaluations of the neutral products from attempted cyclisations:

Brockmann method	4.8
Acid chloride	4.0, 5.7
<i>NN'</i> -Dicyclohexylcarbodi-imide	3.2, 5.0
<i>NN'</i> -Carbonyldi-imidazole	2.9, 4.2, 6.2
Dimethylformamide dineopentyl acetal	2.8, 4.6
2,4,6-Tri-isopropylbenzenesulphonyl chloride	4.0, 4.7
Polyphosphate ester	4.8, 5.4
Natural isariin	6.6

Chromatographic comparisons of (a) D-3-hydroxydodecanoylglycyl-L-valyl-D-leucyl-L-alanyl-L-valine methyl ester, (b) a 50 : 50 mixture of methyl isariate and D-3-hydroxydodecanoylglycyl-L-valyl-D-leucyl-L-alanyl-L-valine methyl ester, and (c) a 50 : 50 mixture of methyl isariate and L-3-hydroxydodecanoylglycyl-L-valyl-D-leucyl-L-alanyl-L-valine methyl ester were made by using the preparative column system in the recycle mode. The following elution volumes (in ml) were observed:

	(a)	(b)	(c) *
Initial	144	148	144
1st recycle	296	300	294
2nd recycle	444	452	442
3rd recycle	596	608	592
4th recycle	748	760	738
5th recycle	900	916	888

\* Complete separation was achieved after ten recycles.

**Mass Spectra.**—Comparative mass spectra of samples of D- and L-3-hydroxydodecanoylglycyl-L-valyl-D-leucyl-L-alanyl-L-valine methyl ester were recorded on an MS-902 instrument by the Physico-Chemical Measurements Unit at Harwell. Chloroform solutions were used to transfer the sample to the probe. The spectra obtained by using an ion source temperature of 200° and an electron energy

of 70 eV were similar to that published<sup>9</sup> for methyl isariate. The relative intensities of the peaks in our spectra at *m/e* 521, 450, 337, 238, and 181 were all lower, but since these correspond to peaks due to simple cleavage of the peptide bonds (*m/e* 539, 468, 355, 256, and 199) but differ in that dehydration of the hydroxy-acid has also occurred, this simply reflects rather less dehydration under the conditions used in our determination.

**Attempted Cyclisation of D-3-Hydroxydodecanoylglycyl-L-valyl-D-leucyl-L-alanyl-L-valine (IV).**—In each reaction the neutral products were isolated by solvent extraction, *i.e.* washing a chloroform solution successively with 2M-hydrochloric acid, water, m-sodium hydrogen carbonate, water, and brine. The washed solution was then dried and evaporated.

(a) **Brockmann method.**<sup>23</sup> A solution of imidazole (269.5 g) in dry tetrahydrofuran (3.3 l) was mixed with acetyl chloride (140.8 ml). The mixture was stirred at 55° for 1 h, filtered, mixed with more acetyl chloride (211 ml), and stirred at 55° for a further 1 h. Part of this solution (1.45 l) was added with stirring to a solution of the peptolide (IV) (2.0 g, 3.06 mmol) in dry tetrahydrofuran (500 ml) at 55°. The mixture was kept at 55° for 2 h, then evaporated, and neutral material was isolated by solvent extraction. The crude residue (160 mg) was triturated with light petroleum (b.p. 40–60°) and filtered off. This product was subjected to preparative h.p.l.c. None of the components present had a retention time corresponding to natural isariin. There was one major fraction (91 mg, 4.7%), m.p. 182–184°,  $[\alpha]_D^{24}$   $+19.8^\circ$  (*c* 0.96 in CHCl<sub>3</sub>),  $\nu_{\max}$  (KBr) 3280, 3065, 1735, 1630, 1530, and 1238 cm<sup>-1</sup> (Found: *m/e*, 537. C<sub>33</sub>H<sub>59</sub>N<sub>5</sub>O<sub>7</sub> requires *M*, 637) (amino-acid ratio Gly, 1.00; Ala, 0.05; Val, 1.00; Leu, 1.00). L-3-Hydroxydodecanoylglycyl-L-valyl-D-leucyl-L-alanyl-L-valine (2.0 g, 3.06 mmol) was treated in a similar way to its epimer (IV). Purification of the crude neutral product (42 mg, 2.2%) by h.p.l.c. gave one major fraction (30 mg, 1.5%), m.p. 122–125°,  $[\alpha]_D^{24}$   $+13.9^\circ$  (*c* 0.14 in CHCl<sub>3</sub>),  $\nu_{\max}$  (KBr) 3280, 3080, 1735, 1630, 1535, 1235, and 1020 cm<sup>-1</sup> (Found: *m/e*, 637. C<sub>33</sub>H<sub>59</sub>N<sub>5</sub>O<sub>7</sub> requires *M*, 637) (amino-acid ratio Gly, 1.00; Ala, 0.24; Val, 1.05; Leu, 1.00).

(b) **Acid chloride method.**<sup>35</sup> The peptolide (IV) (100 mg, 0.153 mmol) was dissolved in thionyl chloride (2 ml) and kept at 20°. The reaction was monitored by i.r. spectroscopy (disappearance of carboxylic acid peak at 1740 cm<sup>-1</sup> and appearance of acid chloride peak at 1795 cm<sup>-1</sup>). After 3 h the solvent was evaporated off, and a little toluene was added and evaporated off. Several repetitions of this procedure left the solid acid chloride, which was dissolved in dry benzene (50 ml) and added simultaneously with a solution of triethylamine (0.022 ml, 0.157 mmol) in benzene (50 ml) to stirred dry benzene (630 ml) over 7 h at 20°. The benzene was evaporated off and the residue worked-up by solvent extraction. The neutral product (60 mg, 31%) on analytical h.p.l.c. showed two components, neither of which had a retention volume corresponding to isariin.

(c) **Dicyclohexylcarbodi-imide method.**<sup>25</sup> A solution of the peptolide (IV) (0.10 g, 0.153 mmol) in acetonitrile (70 ml) and tetrahydrofuran (20 ml) was cooled to –5°, and dicyclohexylcarbodi-imide (0.032 g, 0.0765 mol) in tetrahydrofuran (2 ml) was added. The resulting mixture was stirred at –5° for 30 min, poured into dry pyridine (500 ml), and then heated to 90° for 2 h. The solvent was evaporated

<sup>35</sup> G. Losse and G. Backmann, *Chem. Ber.*, 1964, **97**, 2671.

off and the neutral products were isolated by solvent extraction. The mixture was dissolved in the minimum quantity of acetone and kept at 4° for 12 h before filtering off dicyclohexylurea. Evaporation of the acetone left the crude product (18 mg, 18.5%). Chromatography of this on silica gel (Merck Kieselgel G; 20 g; 30 × 3 cm<sup>3</sup>) with chloroform-methanol (95 : 5 v/v) as eluant afforded a single fraction (2 mg, 2%), whose retention time on h.p.l.c. distinguished it from isariin. (Presumably the bulk of the product was dicyclohexylurea, which is slow to be eluted under these conditions.)

(d) *NN'-Carbonyldi-imidazole*.<sup>24</sup> To a solution of the peptolide (IV) (0.20 g, 0.306 mmol) in dry tetrahydrofuran (600 ml) was added *NN'*-carbonyldi-imidazole (0.55 g, 0.337 mmol). The solution was stirred for 30 min at 20°, and a solution of sodium imidazolide (0.06 ml) was added. This latter was a portion of a solution prepared by dissolving sodium (0.4 g) and imidazole (4.0 g) in dry tetrahydrofuran (20 ml). The mixture was kept at 20° for 5 days, then evaporated, and the residue was worked up for neutral material by solvent extraction. The crude product (50 mg, 25.6%) showed three peaks on h.p.l.c., none of which corresponded to isariin.

(e) *Dimethylformamide dineopentyl acetal*.<sup>27</sup> The peptolide (IV) (0.20 g, 0.306 mmol) was dissolved in dichloromethane (500 ml) and dimethylformamide dineopentyl acetal (0.11 ml, 0.337 mmol) was added to the stirred solution. The mixture was kept at 20° for 5 days then evaporated, and the neutral product was isolated by solvent extraction. The residual material (42 mg, 2.2%) on h.p.l.c. showed no material corresponding to isariin.

(f) *2,4,6-Tri-isopropylbenzenesulphonyl chloride*.<sup>28</sup> To a solution of the peptolide (IV) (0.20 g, 0.306 mmol) in anhydrous pyridine (30 ml) was added 2,4,6-tri-isopropylbenzenesulphonyl chloride (0.139 g, 0.459 mmol). The mixture was stirred at 20° for 30 min then poured into pyridine (500 ml) and kept at 20° for 3 days. The solvent was evaporated off; the crude product obtained by solvent extraction showed no component comparable to isariin on h.p.l.c. Chromatography on silica gel (Merck Kieselgel G; 10 g; 3 × 30 cm) with chloroform-methanol (9 : 1 v/v) as eluant gave a major component (53 mg) which crystallised from aqueous ethanol as needles, m.p. 124–125°. The properties of this were as expected for the *O-tri-isopropylphenylsulphonyl derivative* of (IV),  $\nu_{\max}$  (KBr) 3270, 1730, 1703, 1675, 1630, 1559, and 1152 cm<sup>-1</sup> (Found: C, 62.4; H, 9.2; N, 6.8. C<sub>48</sub>H<sub>83</sub>N<sub>5</sub>O<sub>10</sub>S requires C, 62.5; H, 9.1; N, 7.6%).

(g) *Polyphosphate ester*.<sup>28</sup> Phosphorus pentoxide (3 g) was boiled under reflux in chloroform (3 ml) and diethyl ether (6 ml) until the solution was clear (12 h). The solvent was evaporated off, and part of the residual syrup (0.6 g) added to a stirred solution of the peptolide (IV) (0.20 g, 0.306 mmol) in dichloromethane (600 ml). The mixture was kept at 20° for 5 days, then evaporated. Solvent extraction work-up yielded a product (50 mg, 25.6%) which was clearly distinguishable from isariin on h.p.l.c.

We thank Professor L. C. Vining for a gift of isariic acid and Dr. D. H. G. Crout for assistance with high pressure liquid chromatography.

[3/2355 Received, 16th November, 1973]